

# CADPIPE 8.0

## 3D DESIGN

### Tutorial



---

# Introduction

---

This Tutorial is a brief introduction to the power of CADPIPE 2004 3D DESIGN. We will show you a few key features and the general procedures for creating 3D piping designs. This is not an AutoCAD tutorial. You must have a basic working knowledge of AutoCAD in order to use CADPIPE and to fully benefit from this Tutorial.

## Command Access

---

You can use CADPIPE with a mouse, choosing all commands from the pull-down menus.

CADPIPE 3D DESIGN also offers toolbars, with buttons for specific commands. Next to each pull-down menu command the corresponding toolbar button will be shown:



Select “Specifications” from the “3DDesign” menu.

## Responding to Prompts

---

All text that appears on the computer screen is set apart from the explanatory body copy: we use a different type style.

The appropriate response to a prompt is in bold. The metric equivalent to an imperial entry is in brackets:

Prompt: **RESPONSE** <Return> (1050)

When you are required to pick a point on the drawing, we indicate the point in the text by <P1>, <P2>, etc., and then show the corresponding “P” point in an illustration.

For example:

Column/First Point for Beam: MID of <P1>  
(Using OSNAP MIDpoint, pick the center of the inner face of the upright beam A4, <P1>.)

Elevation of Beam <1'-0">: **13'** (3962) (Enter 13' for the beam elevation.)

For accuracy, place fittings with the aid of OSNAP OVERRIDES. With a two-button mouse, you can hold down the <Shift> key on the keyboard while pressing the right mouse button. This will call up the OSNAPS menu.

## Angle of Rotation

---

For angle of rotation, your system must be set to the AutoCAD defaults:

---

East 3 o'clock = 0°  
North 12 o'clock = 90°  
West 9 o'clock = 180°  
South 6 o'clock = 270°

---

## Getting Started

---

### Running the CADPIPE Demonstration Version

---

If you are evaluating the CADPIPE programs and are running CADPIPE without hardware locks, you will be restricted to a 25 day demonstration period. During the setup, select the 'Imperial Demo' version.

- ▶ Place the CADPIPE CD into the CD-ROM drive. The CD should start on its own. If not, continue with the following prompts.
- ▶ Click "Run" in the "Start" menu.
- ▶ Type **c:install** (where **c:** is the letter of the disk drive).
- ▶ Click "OK."

### Create a New Drawing

---

- ▶ Click the 3D Design icon in the Windows Program Manager.
- ▶ The base and completed tutorial drawings should be listed in the "3DDES Drawings" window of the CADPIPE Project Manager. Select **3DBASE (M3DBASE)**, and click "Launch 3D DESIGN."
- ▶ Once you have completed the tutorial and you are ready to begin drawing on your own, you create a new drawing by clicking "Create Dwg" and entering an original name in the "Name" field and clicking "OK." Then highlight the name in the "Drawings" window and click "Launch 3D Design."

### Views

---

The 3D DESIGN Tutorial is displayed in plan view, and concurrently, in an isometric 3D view. The base drawing has two viewports: PORT 1 (plan) and PORT 2 (isometric).

Following are the CADPIPE 3D DESIGN base and finished drawings. Refer to the finished drawing throughout the Tutorial.

The finished and base drawing files are stored in the \3DDES directory off the main CADPIPE directory and are called 3DDONE.DWG (M3DDONE.DWG in metric CADPIPE) and 3DBASE.DWG (M3DBASE.DWG in metric CADPIPE).

---

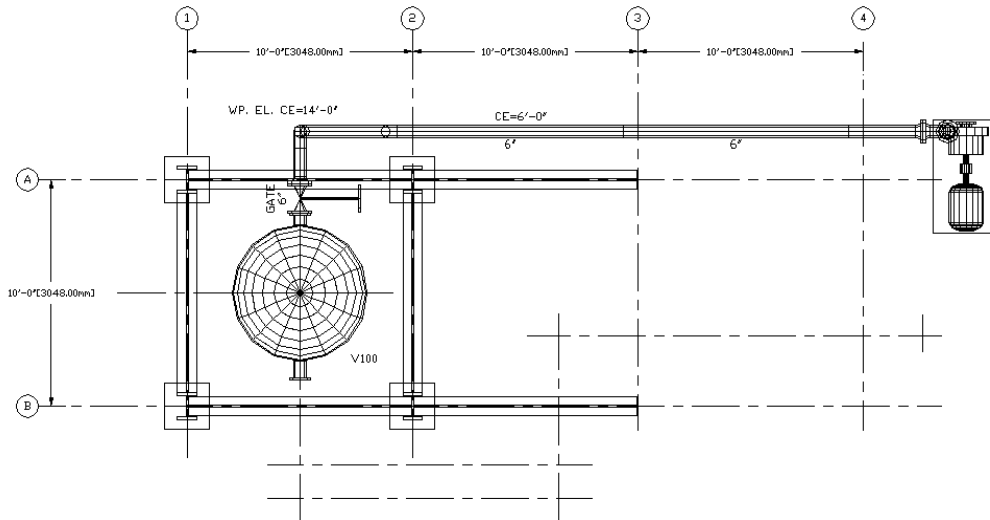

The base drawing for the 3D Design tutorial **PORT1**

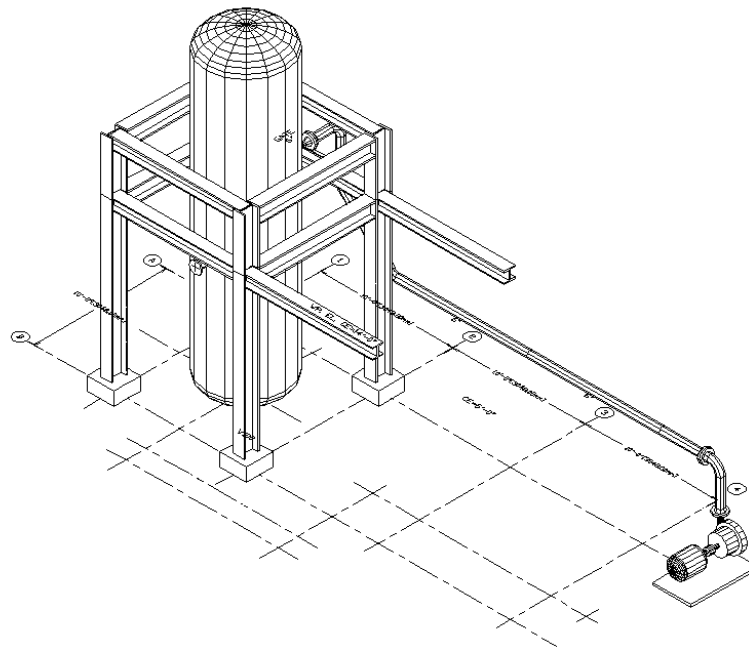

The base drawing for the 3D Design tutorial **PORT2**



## Place Column Bases

First, place four column bases at A4, B4, A3, and B3 on the column grid. The bases are drawn as columns and are placed on layer labeled COLUMN. Click in PORT 1. Refer to

Figure 1.

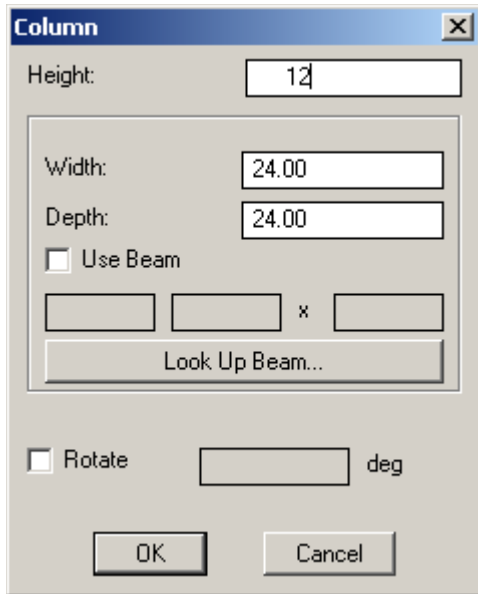

Pick “Columns” from the “STRUCT” menu.

Point for Column: INT of <P1>  
*(Using OSNAP INTersection, pick <P1> in Figure 1.  
 This is the center point for the column.)*

Base Elevation of Column <0.00>: 0  
*(Type 0 and press Enter to set the base elevation of  
 the column.)*

In the **Column** dialog box, select the following settings:  
 Height (from 0 elevation to top of column base): **12** (305)  
 Width: **24** (610)  
 Depth: **24** (610)

Click “OK.”

Press <Return> to reenter the Columns command. Using OSNAP INTersection, pick <P2>. In the **Column** dialog box, select the same settings as for the first column base.

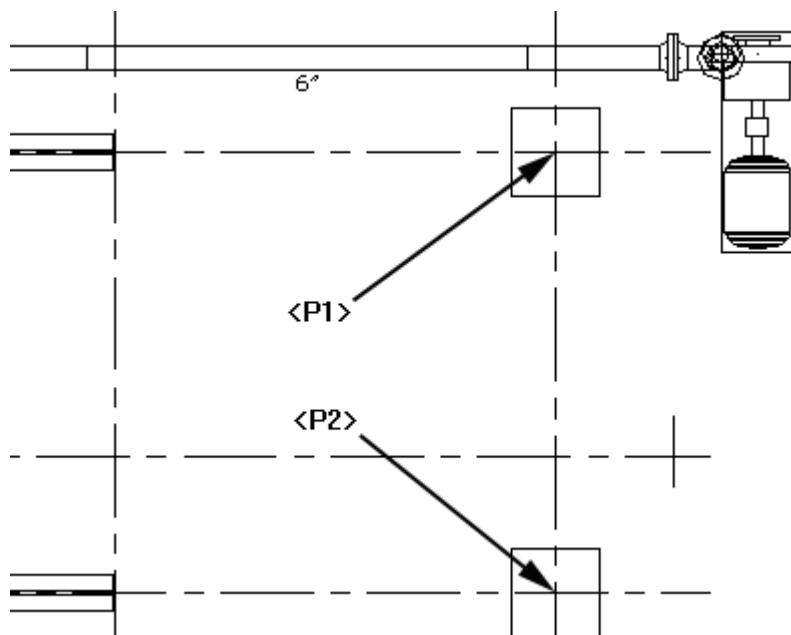

Figure 1



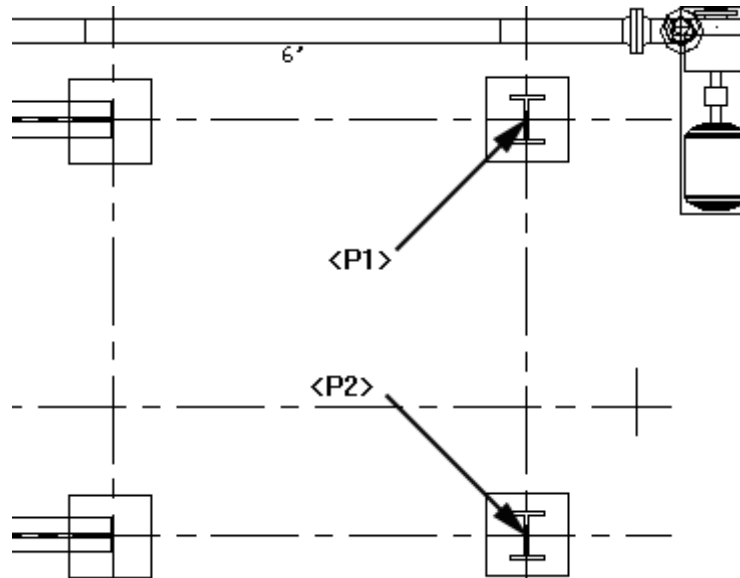
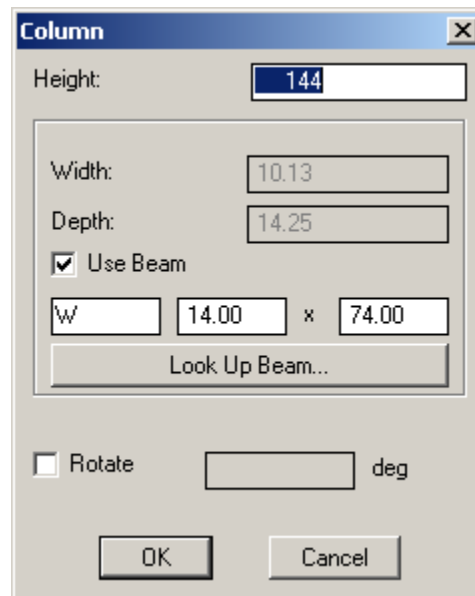

Figure 3

Using OSNAP INTersection, pick <P1>.

Base Elevation of Column <0.00>: 12 (305)  
 (Type 12 and press Enter to set the base elevation.)



The **Column** dialog box appears. Click the **Look up Beam** button.  
 In the **Select Type of Beam** dialog box, click **I-Beam**.

You automatically enter the **Beam Database** dialog box. Select a **W14 x 74** (DEM 257 x 362) I-beam from the Beam Database, and click OK.

This returns you to the **Column** dialog box. Notice the beam name and dimensions are automatically updated. Enter **12'** or **144"** (3658) in the **Height** field to set the column height. Click OK to place the column.

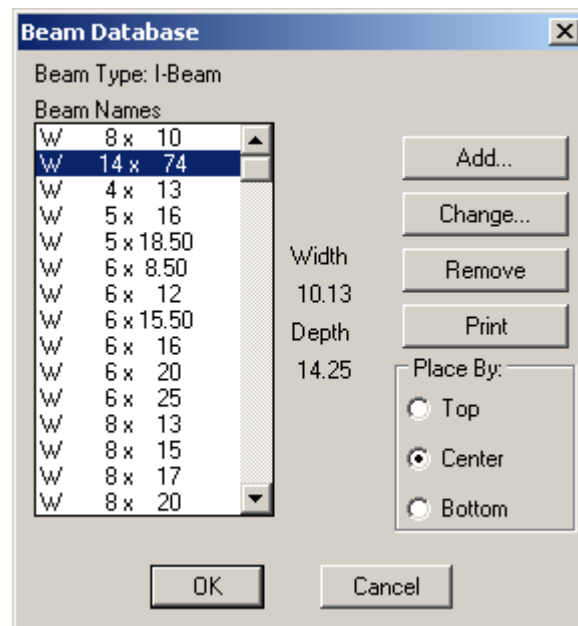
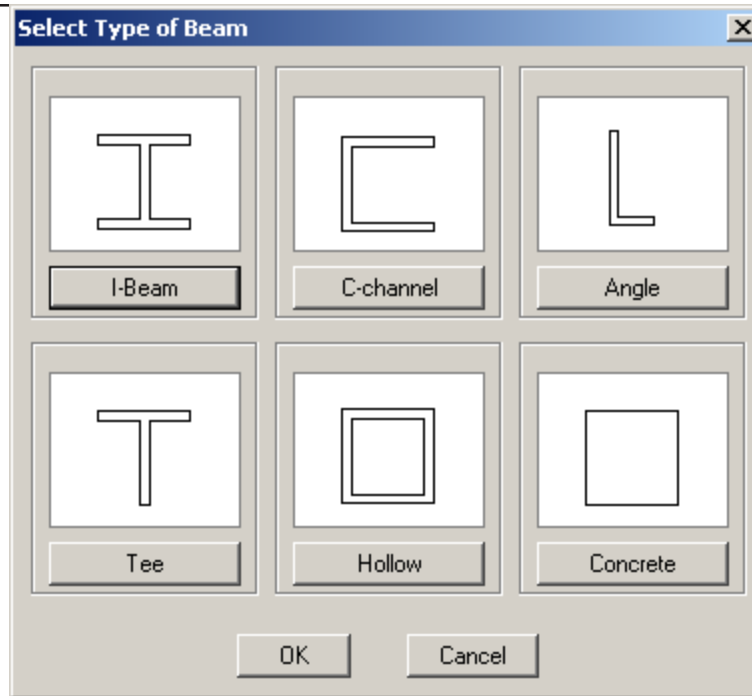

Press <Return> to re-enter the **Column** command.

Place a second column with the same dimensions as the first column at <P2> on Figure 3.

### Copy columns

Copy the columns A4 and B4 to A3 and B3 using the AutoCAD Copy command. Refer to Figure 4.

Select objects:  
 Select objects: 1 found <P1> (Pick the column at <P1>.)  
 Select objects: 1 found, 1 group <P2> (Pick the column at <P2>.)  
 Select objects: 1 found, 1 group, 2 total  
 Select objects: <Return>  
 Specify Base point or displacement, or [Multiple]: INT of <P3>  
 (Using OSNAP INTersection, pick <P3>.)  
 Specify Second point of displacement: INT of <P4>  
 (Using OSNAP INTersection, pick <P4>. You may need to zoom in to pick the inter-  
 section.)

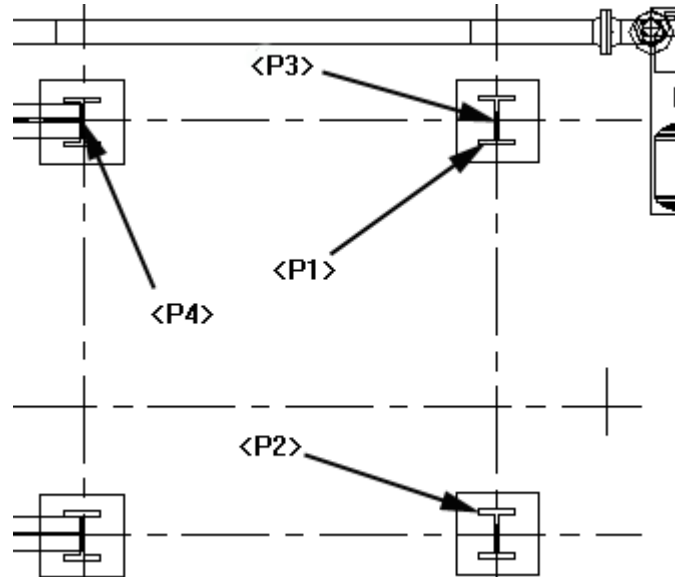

Figure 4

## Place Horizontal Beams

Place the horizontal I-beams from columns 3 to column 4. Refer to Figure 5.

**Select “Beams” from the “STRUCT” menu:**

Pick an I-beam from **Select Type of Beam** dialog box.

Column/First Point for Beam: MID of <P1>  
 (Using OSNAP MIDpoint, pick the center of the inner face of the upright beam A4,  
 <P1>. You may need to zoom in to pick the point.)

Elevation of Beam <1'-0" (305): **13'** (3963)  
 (Enter 13' for the beam elevation.)

Column/Second Point for Beam: MID of <P2>  
 (Using OSNAP MIDpoint, pick the center of the inner face of the upright beam A3,  
 <P2>. You may need to zoom in to pick the point.)

Elevation of Other End <13'-0">: <Return>  
 (Accept the default 13' (3963) for the ending elevation of the beam.)

Beam Number or Size/<Enter for Database>: <Return>  
 (Press <Return> to enter the “Beam Database” dialog box to pick a beam name.)

In the **Beam Database** dialog box, pick a **W 10 x 49** (W 250 x 89) beam. In the **Place By** section, click **Top** to set the elevation to Top of Steel. Click OK.

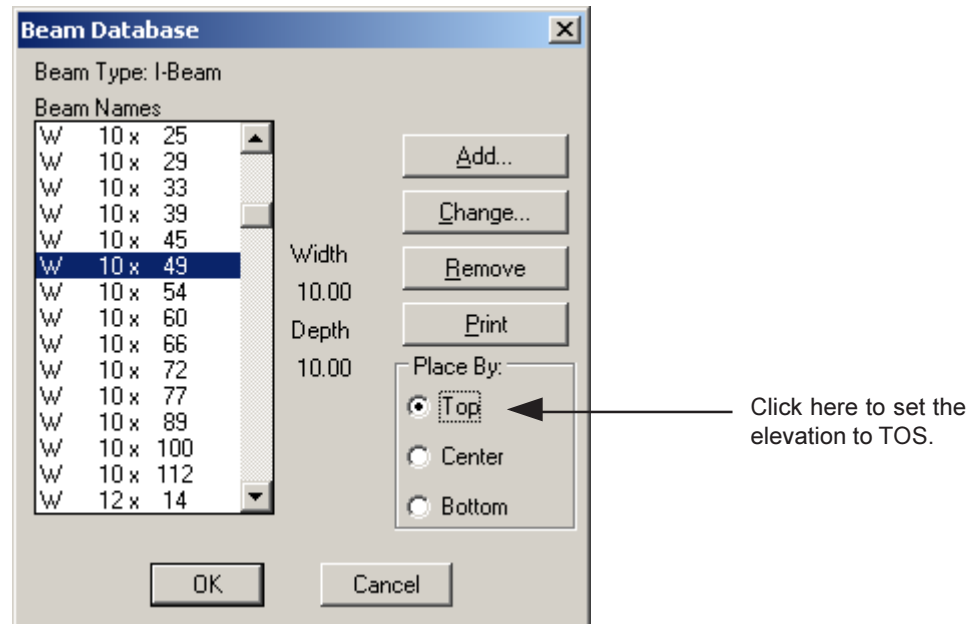

### Place second beam

Using the same procedure as demonstrated above, place the second beam (**W 10 X 49**) (W 250 x 89) at elevation **13'** (3963), **TOS**. Using OSNAP MIDpoint, pick **<P3>** and **<P4>**. Refer to Figure 5.

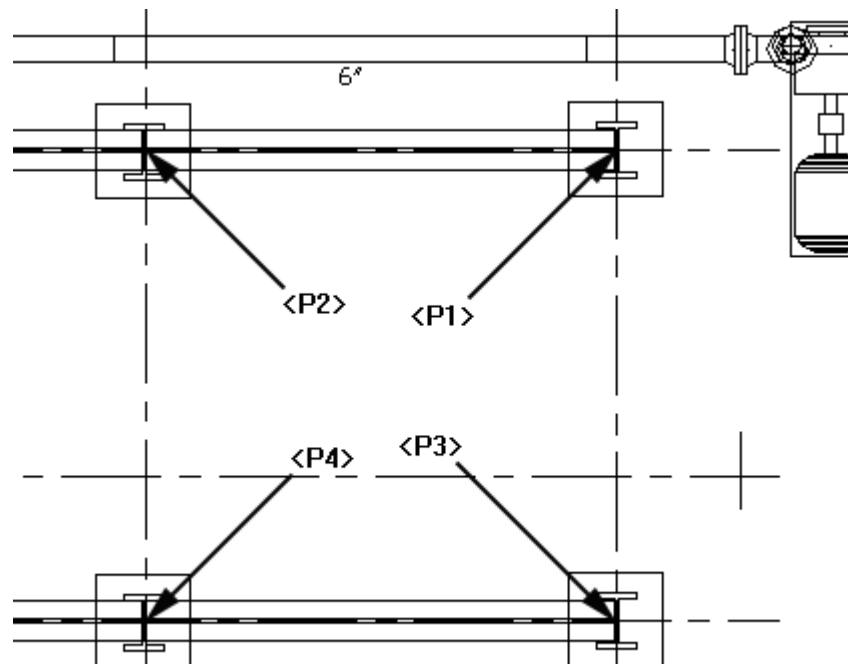

Figure 5

## Place Cross Beams

Using the same procedure as demonstrated above, place the crossbeam (**W 10 X 49**) (W 250 x 89) at elevation **13'** (3963), **TOS**. Using OSNAP MIDpoint, pick points **<P1>**, **<P2>**, **<P3>**, and **<P4>**: Refer to Figure 6.

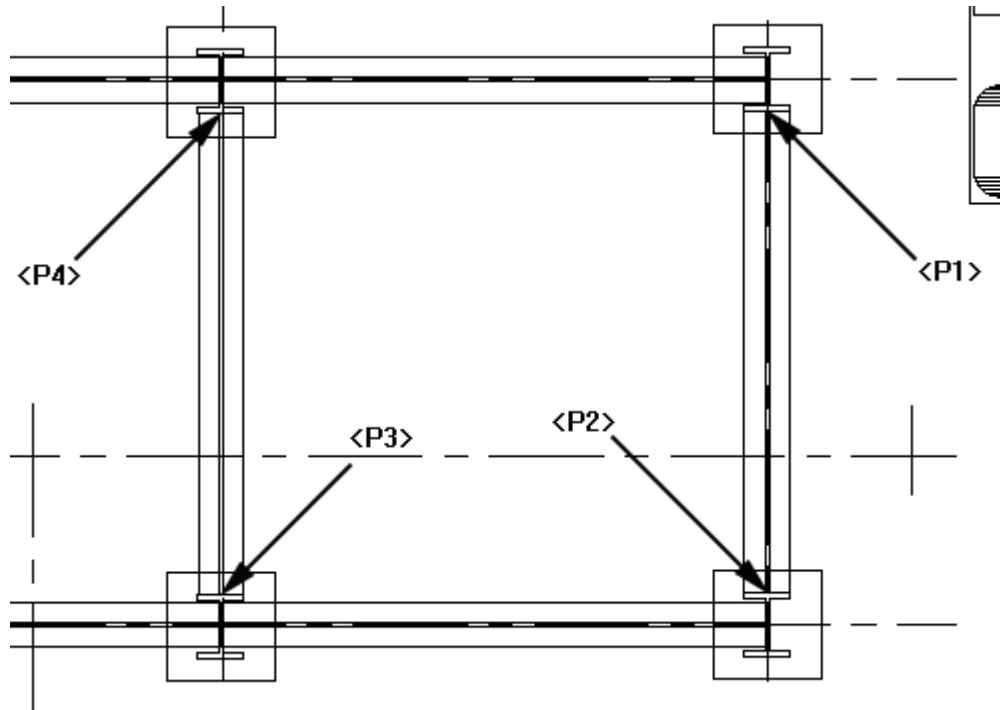
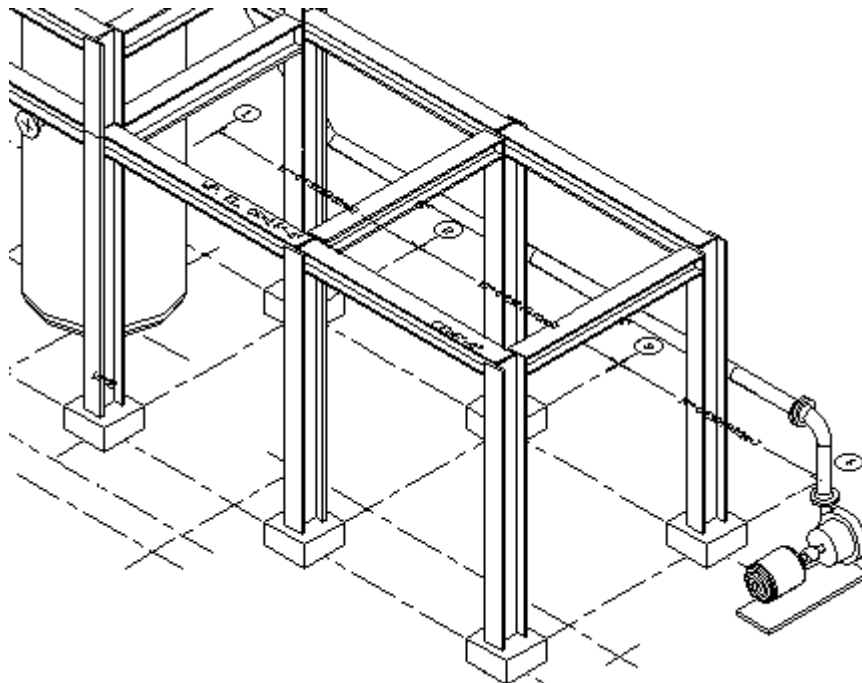

Figure 6

Your drawing should now look like this (in PORT 2):



## Define Design Specifications

Before drawing pipe runs or placing fittings or valves, set the line number, material specification and pipe size.



Select “Specifications” from the “3D Design” menu.

The **Specifications Options** dialog box allows you to change the parameters that define the pipe or fittings you are drawing.

### Set the line number

A line number applies to all piping and fittings. Click in the “Line Number” field and type **TUTOR1**. This number applies to all items we place on the drawing until the line number is renamed.

---

## Set the material spec

---

Next, set the material specification. Click the “List” button next to the “Material Spec” field. Pick specification “abb1” from the “Material Spec Files” dialog box, and click “OK.”

ABB1 is one of the many specifications that are supplied with CADPIPE. The specifications contain predefined settings for valves, fittings, and pipe. When the Spec Check command is on, the specification automatically sets defaults such as rating, end type, and schedule.

---

## Turn Spec Check on

---

In CADPIPE, the designer can either access everything in the database, or apply a standard specification to restrict the items that can be placed, or use a combination of both. We will place items on the Tutorial drawing with the **Spec Check** command on. This means that many of the defaults (end type, schedule, rating, etc.) are set automatically by the program according to what is defined in the material specification file for specification ABB1. In the “Specification Options” dialog box, click the box beside “Spec Check.” A checkmark indicates that Spec Check is active.

---

## Turn Spec Alternate off

---

The Spec Alternate toggle lets you place fittings that are entered as alternates in the specification when Spec Check is on. Any fittings or valves that are different from the default but contained in the spec are displayed in the “Select Alternate Fitting Type” dialog box. We are only placing default fittings and valves, so make sure this toggle is off.

---

## Set the pipe size

---

If the size is not already set to 6", click the arrow next to “Pipe Size” and pick 6" (150mm). Once you have set the necessary parameters, click “OK” to exit.

---

## Set the elevation

---

Next, ensure the working elevation is 10'. Type “Elevation” at command prompt.

Command: **Elevation <Return>**

Enter new value for Elevation <0'-0">: **10' <Return>** (3048)

*(Enter elevations in feet (') and inches ("). For example, if you were to enter 20 without the symbol for feet, the program would return 1'-8". In metric CADPIPE, all units are entered in millimeters. You do not have to include "mm" at the end of your entry.)*

---

## Piping Layout

### Draw Routing Line

CADPIPE can use an intelligent 3D line (routing line) to represent a run of pipe. Items placed on the routing line automatically adopt the intelligence (material spec and line number) of the line. Having drawn your routing line, you can place elbows, valves, flanges, fittings, and pipe. You can place horizontal, vertical, rolled, and sloped routing lines. We will draw a Routing Line shown in Figure 8.

Select "Routing Line" from the "Place" menu.

```

Elevation <10'-0"> (3048)
Line Designation: <TUTOR1-ABB1>
Pedit/Join/Designation/Elevation/Slope/Reference/<First point>:
INT of <P1> of Figure 8 (Use OSNAP Int to pick the face of the nozzle.)
Elevation/Roll/Slope/Undo/<To point>: <P2>
Elevation/Roll/Slope/Offset-45/Slope/Undo/ (To point) : E <Return>
(Type E to change the elevation of the next segment.)
Digitize new elevation <KB Option>: NEAREST to <Return>
(Press <Return> to type in the new elevation. You could also digitize an item on the drawing to
set your elevation to that contained in the item selected.)
Enter new Elevation<10'-0">: 1'6" <Return> (450)
Elevation <1'-6">
Elevation/Roll/Offset-45/Slope/Undo/<To point>: <P3>
Elevation/Roll/Offset-45/Slope/Undo/<To Point>: E <Return>
(Type E to change the elevation of the next segment.)
Digitize new elevation<KB Option>: NEAREST to <Return>
Enter new Elevation<1'-6">: 13'8" <Return> (4150)
Elevation <13'-8">
Elevation/Roll/Offset-45/Slope/Undo/<To point>: <P4>
Elevation/Roll/Offset-45/Slope/Undo/<To point>: <P5>
Elevation/Roll/Offset-45/Slope/Undo/<To point>: <Return>
  
```

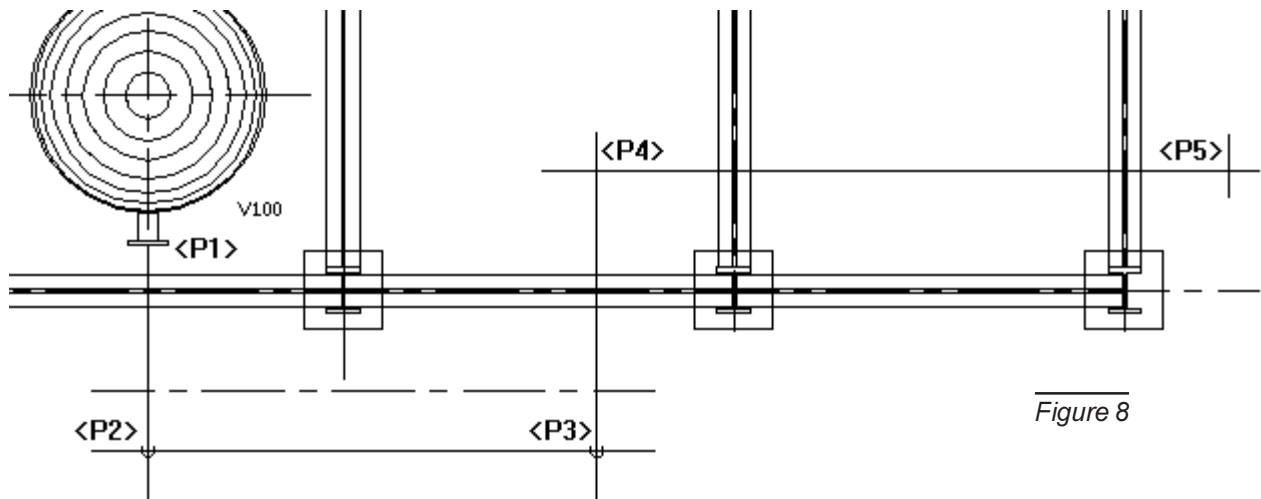

Figure 8

## Place Fittings on the Main Run

### Place Two Flanges

Place a flange on the face of the nozzle and at the end of the routing line. Refer to Figure 9.

**Select Flange from the PLACE menu.**

The **Flange Placement** dialog appears. Choose the **Weld Neck** flange and toggle the insertion point to **Flange Face**, as show in the picture below. Click the **Place** button.

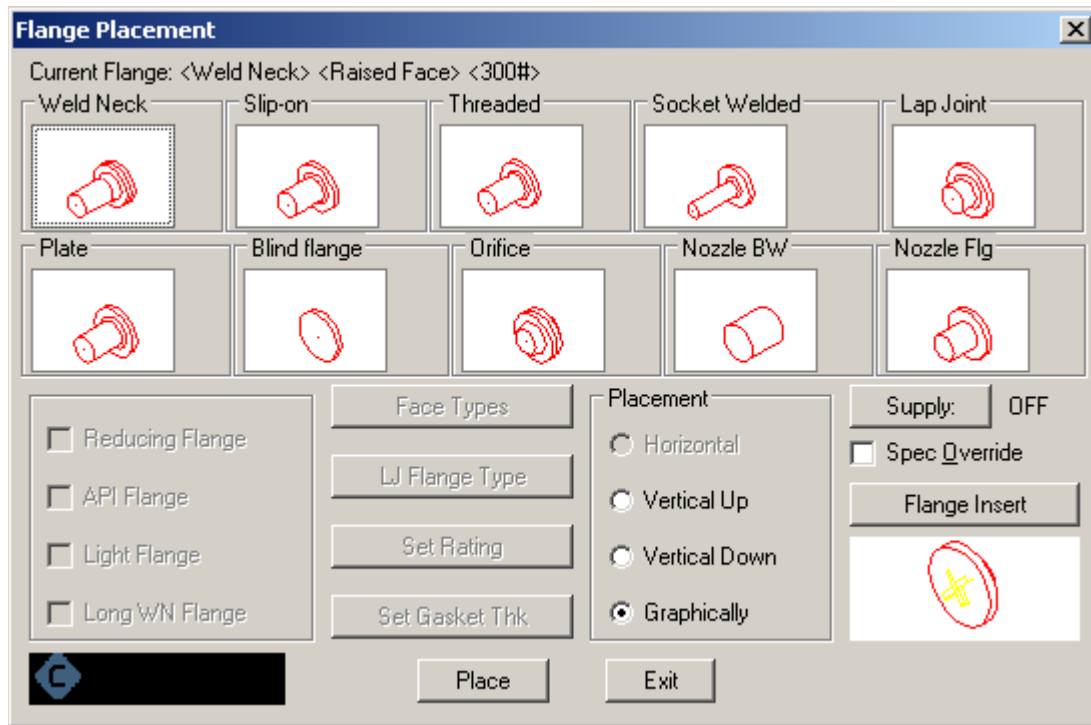

Face of Flange: **<P1>** (Use *OSNAP Int* to pick the face of the nozzle **<P1>**.)

Angle to Butt: (Pick any point along the routing line.)

Now place a second flange at the other end of the routing line:

Command: **<Return>** (Press *<return>* to re-enter the place flange command.)

Face of Flange: **<P2>** (Use *OSNAP Endpoint* to pick the end of the routing line.)

The system asks if you want to change the elevation. Click “Yes,” because the endpoint of the routing line is at a higher elevation than the nozzle.

Angle to Butt: **<P3>** (Pick any point along the routing line.)

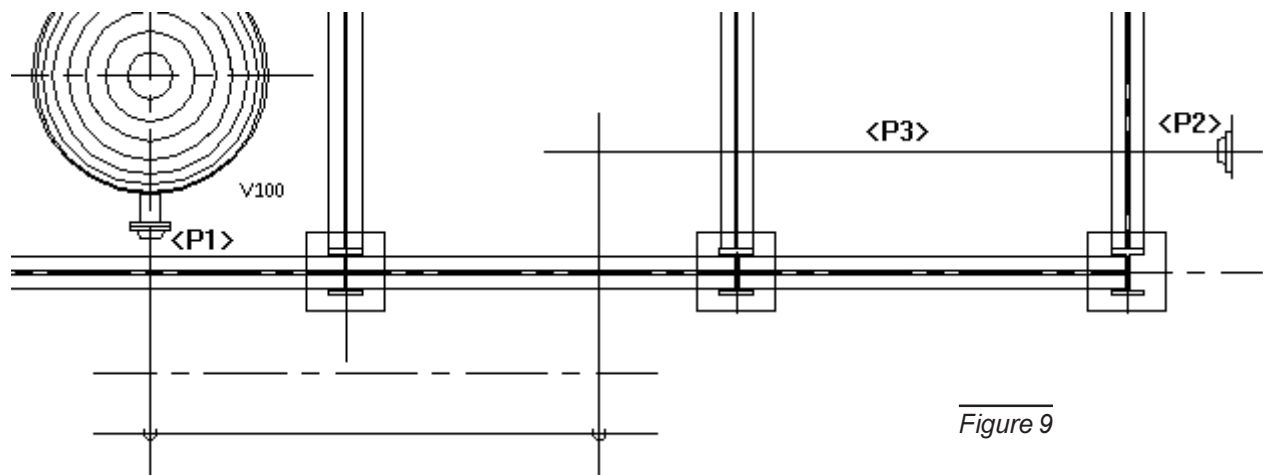

Figure 9

### Place the Globe Valve

First set pipe size to 3" (80mm) in the "3D Design"—"Specifications" dialog box.



Select Valve from the "PLACE" menu.

The **Valve Placement** dialog appears. Choose the **Globe Valve**, toggle the **Valve Config** to **flange on both ends**, and the **Valve Insert** point to **Center** as show in the picture below. Click the **Place** button.

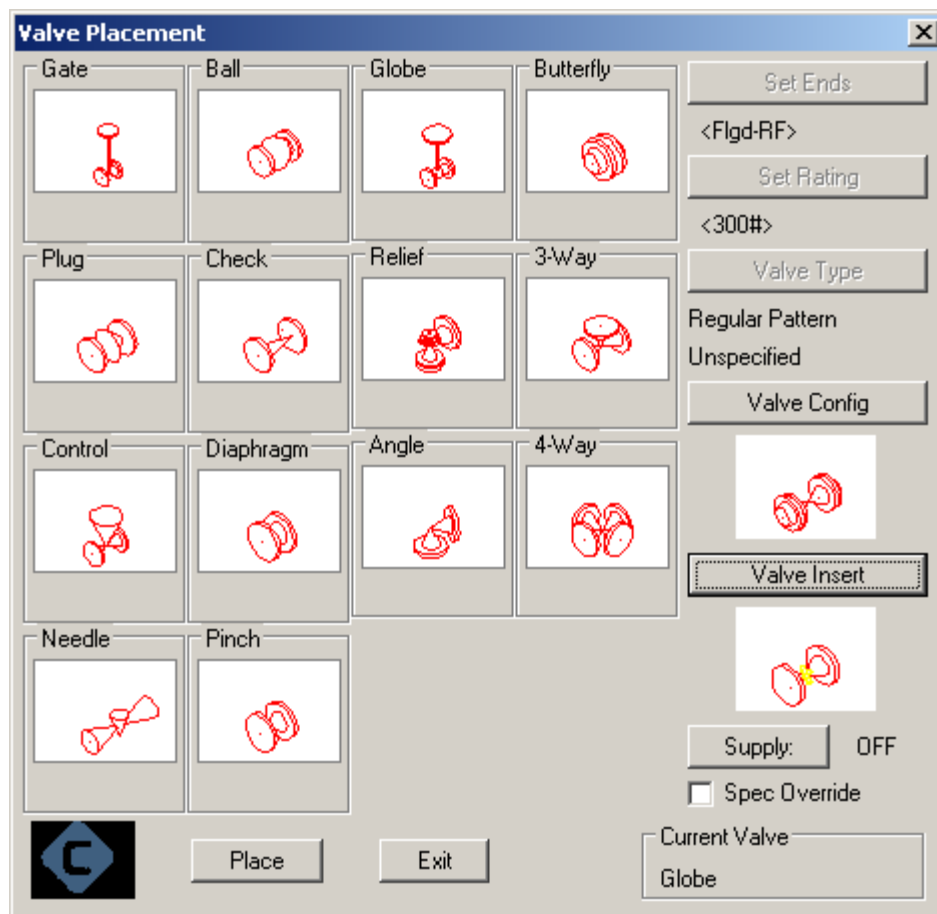

Center point: mid of **<P1>**  
(Use OSNAP midpoint to pick <P1>. Refer to figure 10.)

The system will ask if you want to change the elevation. Click “YES” on elevation change dialog box.

Angle to Outlet Side: **<P2>**  
(select a point along routing line.)

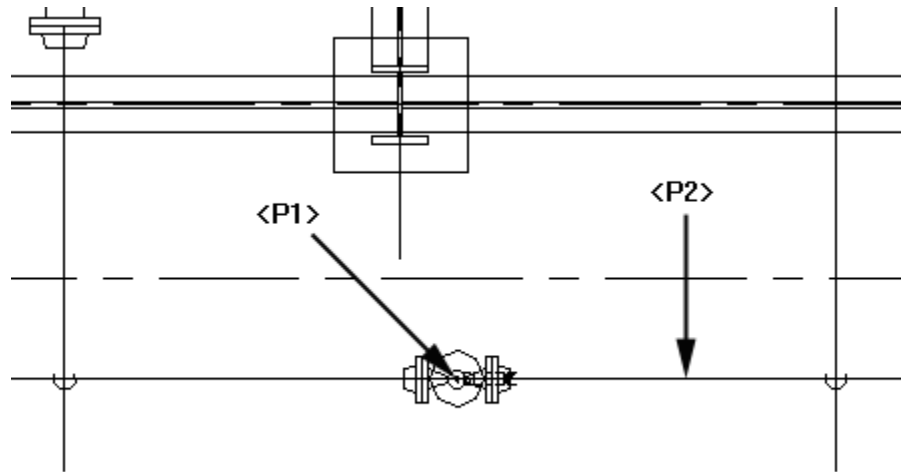
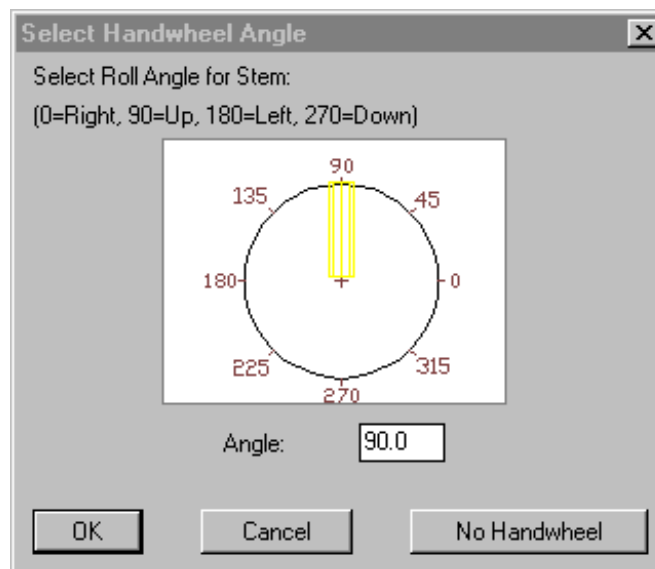

Figure 10

Select **90 degrees** for the stem angle, from the “Select Handwheel Angle” dialog box. Click “OK.”



## Place Reducers

Next, place a concentric reducer on either side of the globe valve. Refer to figure 11.



Pick “Join To” from the “3D Design” menu.

Pipe/Fitting to Join To: <P1>  
(Select the flange on the valve in Figure 11.)

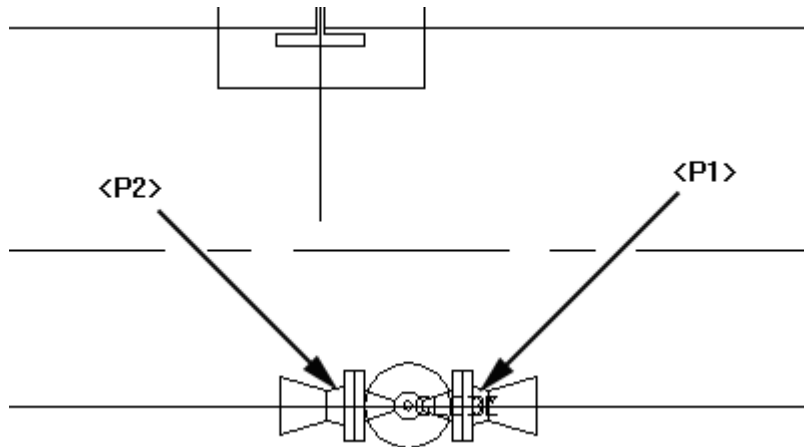
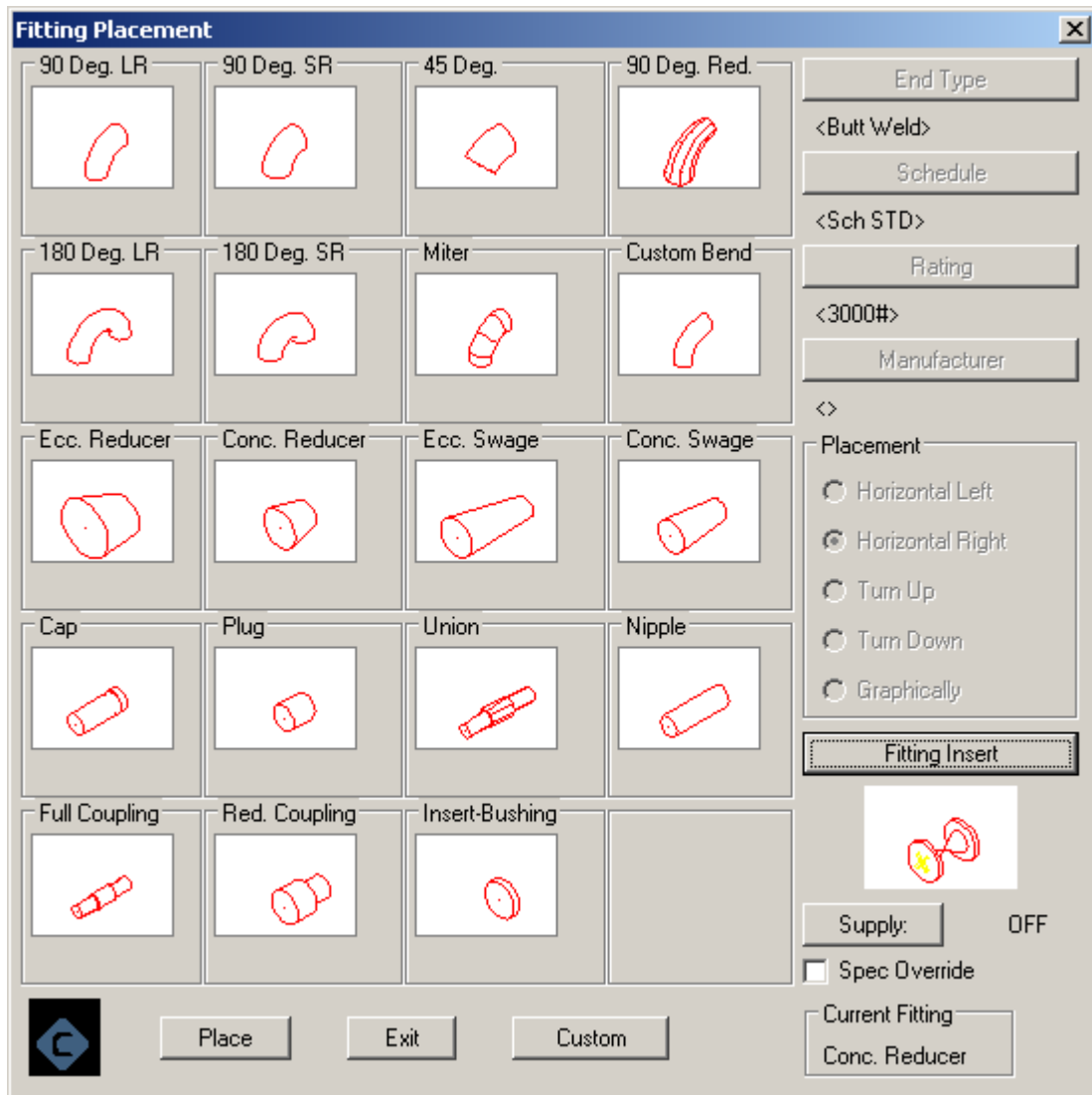

Figure 11

The **Auto-Fit** dialog box appears. Turn Auto-Fit on by clicking **Yes**.

Select “Fitting” from the “Place” menu.

The **Fitting Placement** dialog box appears. Choose the **Conc. Reducer**, toggle the **Fitting Insert** point to **End** as show in the picture below. Click the **Place** button.



A **Reducer Selection** dialog box will pop up. Select **6"** from the **Reduce To:** menu and click OK.

To place a second reducer on the other side of the globe valve, repeat the above steps.



Pick **"Join To"** from the **"3D Design"** menu.

Pipe/Fitting to Join To: **<P2>**  
(Select the flange on the valve in Figure 11.)

Select **"Fitting"** from the **"Place"** menu.

Choose the **Conc. Reducer**, toggle the **Fitting Insert** point to **End** in the **Fitting Placement** dialog box. Click the **Place** button. Choose **6"** in the **Reducer Selection** dialog and click OK.

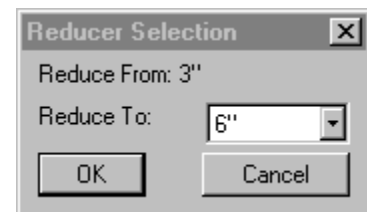

## Place Vertical Fittings

Before Auto-piping the main ruin (TUTOR1-abb1), we will draw the bypass.

### Place Elbows

Place elbows at each vertex of the routing line using the AUTO-ELBOW command.



Select “3DDesign” — “Auto-Elbow.”

Select **Elbow LR** from the **Auto Elbow** dialog box.

Digitize start point on routing line: NEAREST  
(Pick any point along routing line TUTOR1-ABB1.)

Digitize end point on routing line <ALL>:  
NEAREST to **<Return>**  
(Press <Return> to AUTO-ELBOW the entire line and  
<Return> again to exit the Auto-Elbow command.)

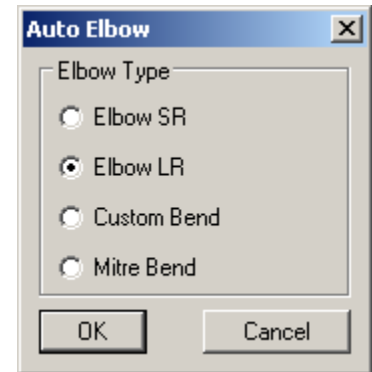

### Left Vertical Segment

We will place a piece of pipe and a valve from the elbow on the left vertical run. Refer to Figure 12.



Pick “Join to” from the “3Ddesign” menu.

Command: Pipe/Fitting to Join to: **<P1>**

Select the entrance of the left elbow, <P1> in Figure 12.

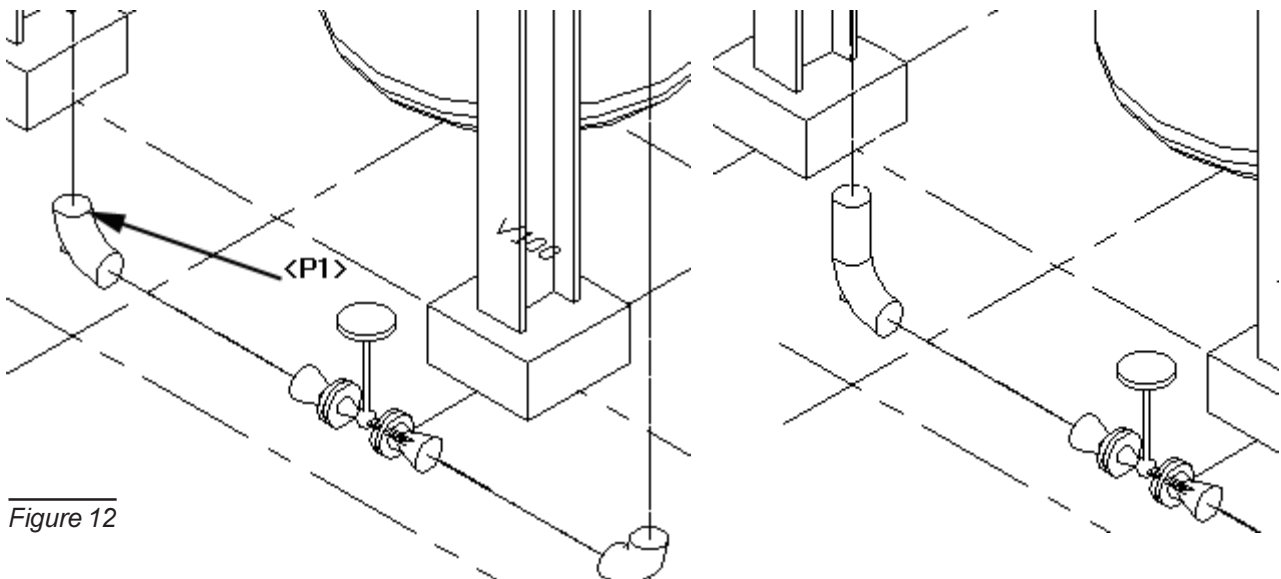

Figure 12



From “Place” menu, pick “Piping,” then “Cut Length.”

Join<Length>: 1' <Return> (305)

*(Type 1' at command prompt, hit return, and one foot of pipe is placed at the end of the elbow. See Figure 12)*



Select “Valve” from the “Place” menu.

In the **Valve Placement** dialog box, choose **Gate Valve**.

Because Spec Check is on, the Valve Pattern (Regular) is already selected for you. From the **Select Handwheel Angle** dialog box, pick **180 degrees**. (This is the direction at which the stem exits the valve in **plan view**. Click Ok.

The valve is joined to the 1' pipe complete with flanges, gaskets, and handwheel. Refer to Figure 14.

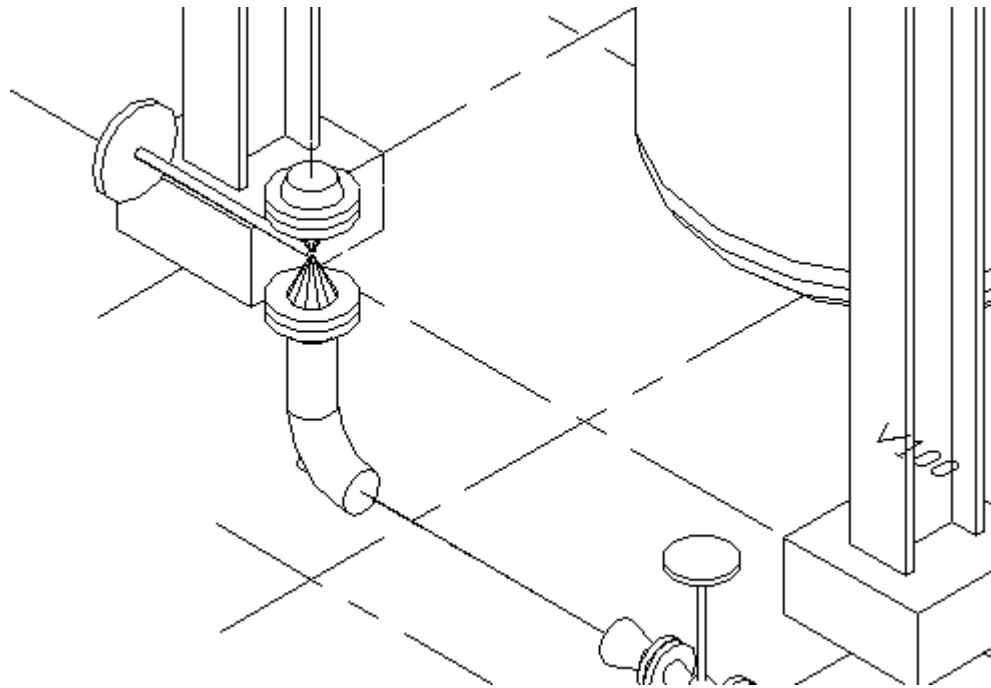

Figure 14

The Next step is to join a 6” x 6” x 3” (150 x 150 x 80) reducing tee to the valve.

From the “Place” menu, pick “branch.”

Inside the **Branch Placement** dialog box, select the **Red. Tee** and click **Place**.

Highlight **6” x 6” x 3”** (150 x 150 x 80) in the **Reducing Fitting Selection** dialog box and click OK.

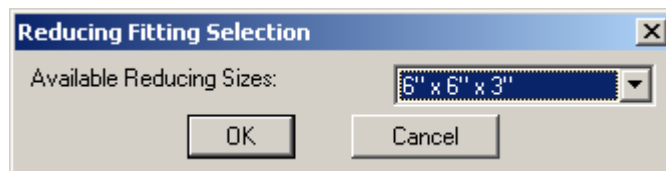

The “Line Designation for Branch” dialog box appears.

Change the branch run Line Number to TUTOR2 and keep the Material Spec the same. Click OK.

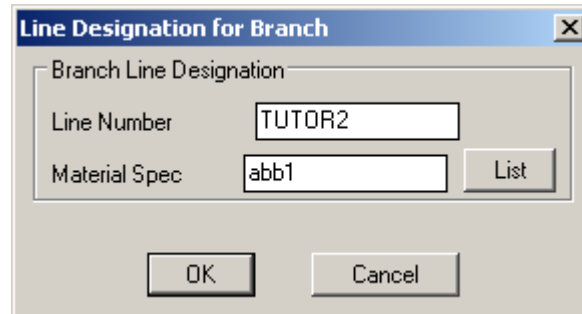

Next, select the rotation angle of the secondary branch (what angle it exits the main run). Select **90 degrees**, and click OK.

CADPIPE places the reducing tee at the end of the valve. Refer to Figure 15.

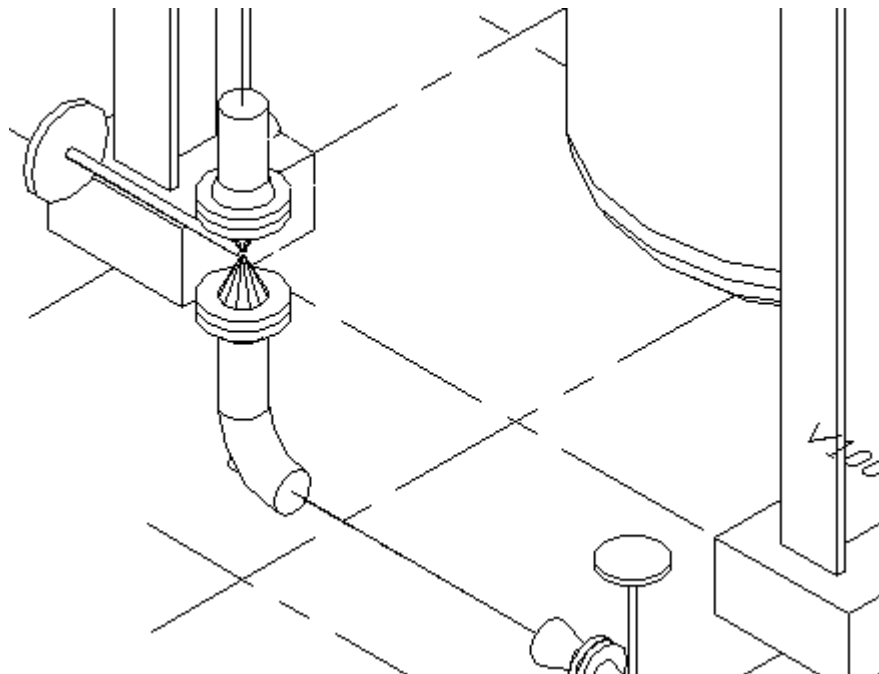

Figure 15

### Right Vertical Segment

Now, using the procedure you just completed to place fittings on the left vertical segment, place fittings on the right side. Refer to Figure 16.

 Pick “Join to” from the “3D Design” menu.

- ▶ Pick the exit end of the right vertical elbow.

 From the “Place” menu, pick “Piping,” then “Cut length.”

- ▶ Type **1’ <Return>** (305) for the length of pipe.

 Pick “Valve” from the “Place” menu.

- ▶ Select the **Gate Valve** icon.
- ▶ Click **Place**.
- ▶ Pick the angle at which the valve stem will exit the valve. Enter **270 degrees**.
- ▶ Click OK.

From the “Place” menu, choose “Branch.”

- ▶ Select the **Red. Tee** icon.
- ▶ Highlight **6” x 6” x 3”** (150 x 150 x 80) in the **Reducing Fitting Selection** dialog.
- ▶ Click OK.
- ▶ Change the branch run Line Number to TUTOR2.
- ▶ Click OK.
- ▶ Select **90 degrees** for the exit angle.
- ▶ Click OK.

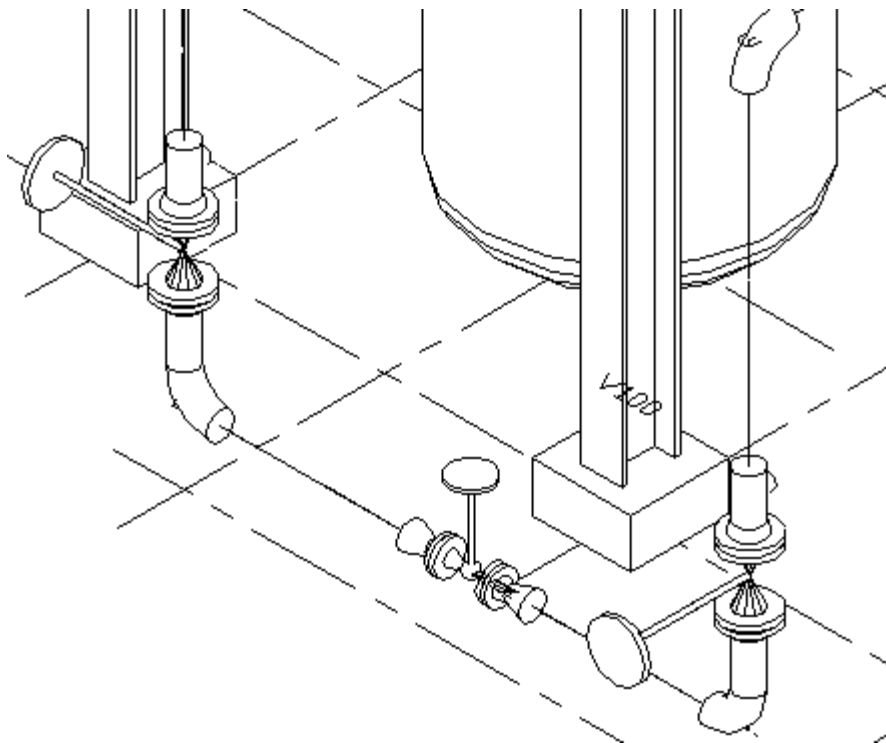

Figure 16

## Place Horizontal Fittings

### Fittings on the Bypass

We will now add some pipe, an elbow, and two valves to the tee.



Select “Join to” from the “3D Design” menu.

Pick the branch of the reducing tee coming off the **left** vertical run, <P1> in Figure 17. The current elevation, line number, size, and end type is updated to match the tee.



From the “Place” menu pick “Piping,” then “Cut Length.”

Join <Length>: **8” (203)** <Return>  
*(An 8” piece of pipe will be added to the tee.)*

Select “Fitting” from the “Place” menu and choose a 90 Deg LR Elbow from the Fitting Placement dialog.

Click the **Place** Button.

We will now place a gate valve and a globe valve on the elbow. Refer to Figure 18.

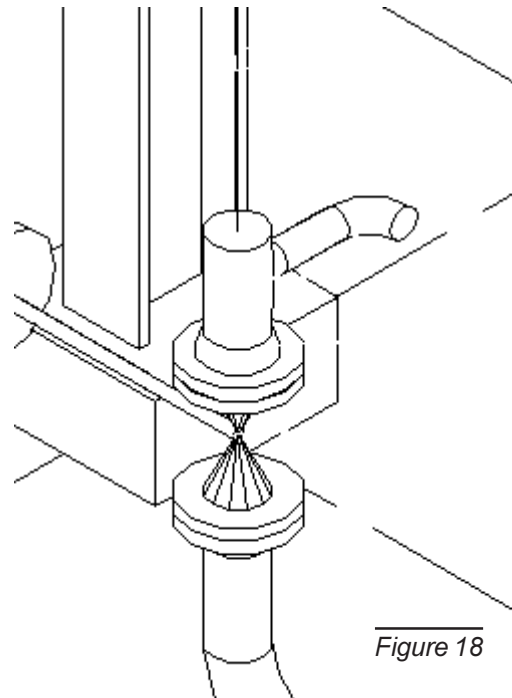
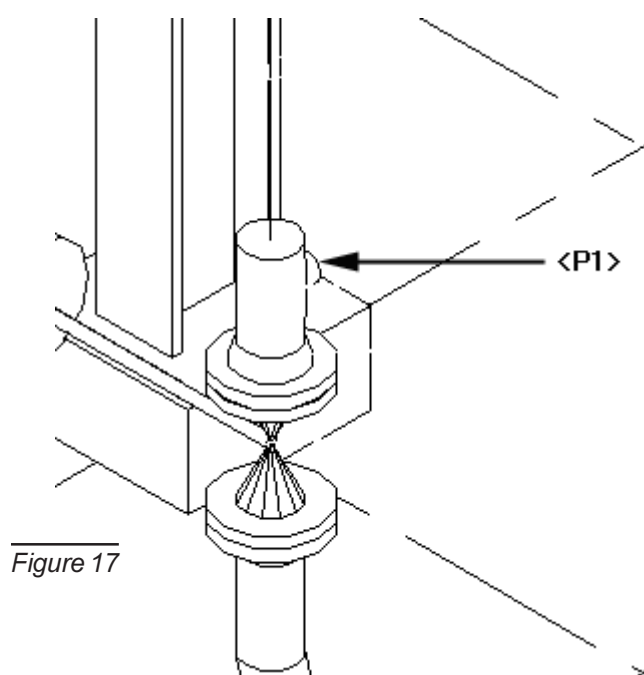

Pick “Valve” from the “Place” menu.

Select the **Gate Valve** icon. Toggle the **Valve Config** so that the valve is placed with only one flange. Refer to Figure 19.

Figure 19

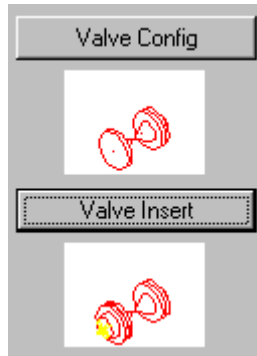

Figure 20



Toggle the **Valve Insert** so that the valve is placed on the flanged side. Refer to figure 19. (Even though the valve icon has two flanges, the valve is placed as shown in the configuration icon with only one flange.)

Click **Place**. Select **0 degrees** for the handwheel angle in the **Select Angle** dialog box, and click OK.



**Pick “Valve” from the “Place” menu.**

Select the **Globe Valve** icon and Toggle the **Valve Insert** so that the valve is placed on the non-flange side, refer to Figure 20. Click **Place**.

Select **0 degrees** for handwheel angle in the **Select Angle** dialog box, and click OK.

To finish placement of the valves, use AutoCADs’ GRIPS to move the valve text to the other side of valves. Refer to Figure 21.

Figure 21

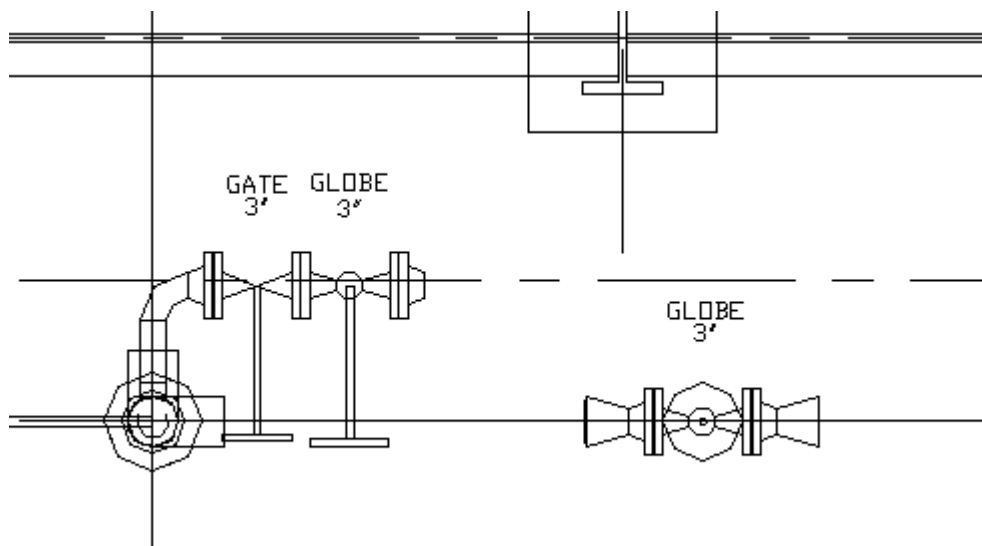

## Auto-Route the Bypass



Pick “Auto-Route” from the “3D Design” menu.

In the **Available Fittings for Auto-Route** dialog box, choose the **90 Degree Long Radius Elbow** and click OK.

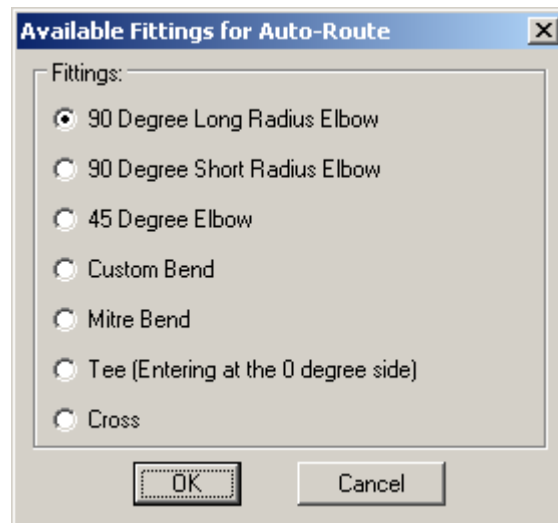

Close/Join/Snap/ Elev/<Next Point>: **J <Return>**  
(Type J <Return> to select the Join option of the Auto-Route Command.)

Pick Pipe/Fitting to Join to:  
(Pick the right reducing tee. Refer to Figure 22.)

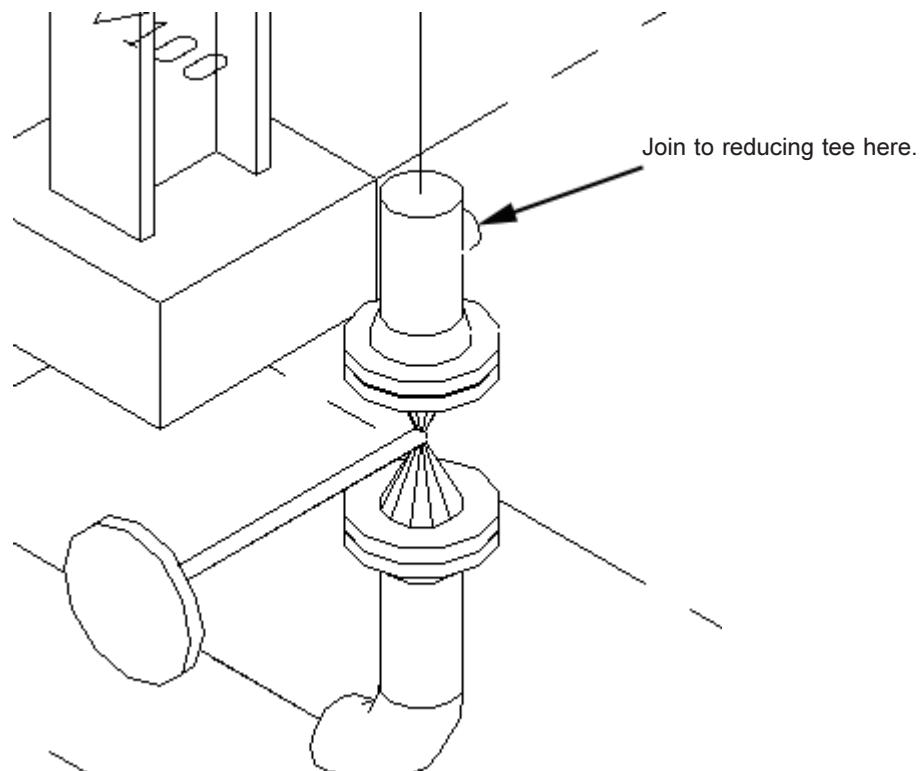

Figure 22

The finished bypass should look like Figure 23.

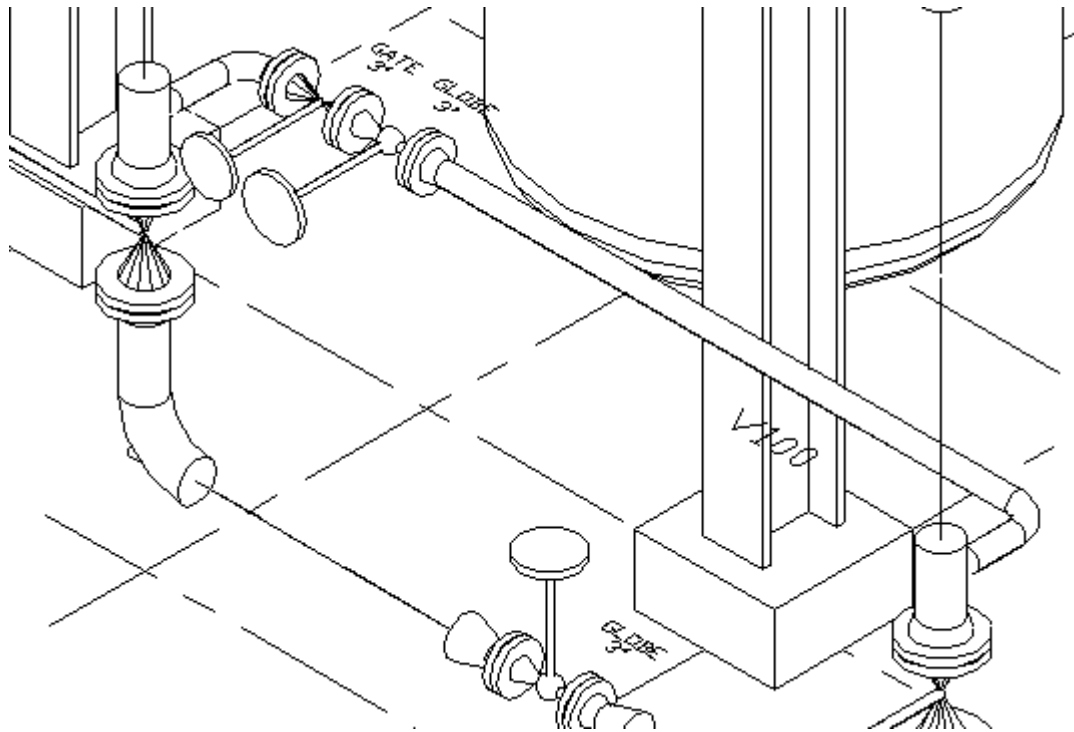

Figure 23

---

## Auto Pipe the Main Run

---

Cadpipe automatically places pipe along a routing line.

### Select "3D Design" "Auto-pipe"

Digitize routing line <Exit>: Nearest to  
(Pick any point along line TUTOR1.)

The system chooses the proper length pipes and places them.

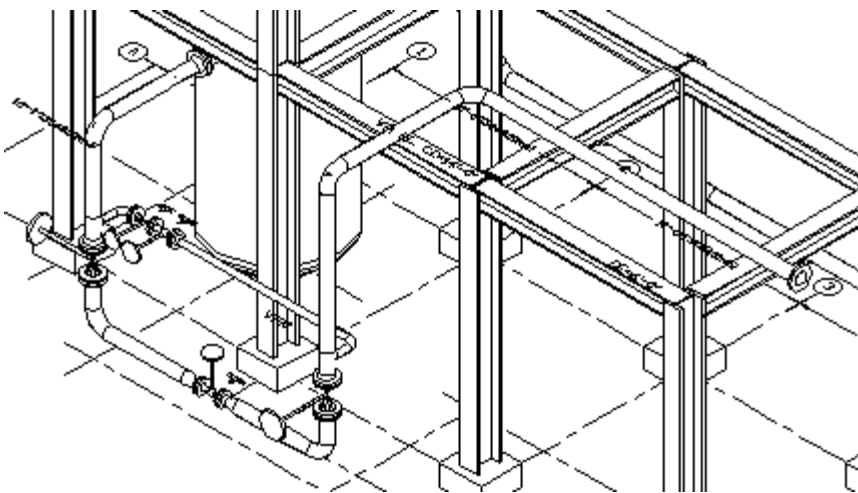

Here are the finished pipe runs TUTOR1 and TUTOR2. Now that the pipe is placed, we will create and label an isometric drawing.

## Automatic Isometric

CADPIPE allows you to easily create and label an isometric drawing.

### Create an Isometric Drawing

The **Iso Pipe** command allows you to create a quick isometric view of any section of pipe while in plan view, without having to rotate or change AutoCAD View-Ports.



Pick “Iso Pipe” from the “TOOLS” menu:

In the **Isometric 3D Design** dialog box, define the type of projection you want:

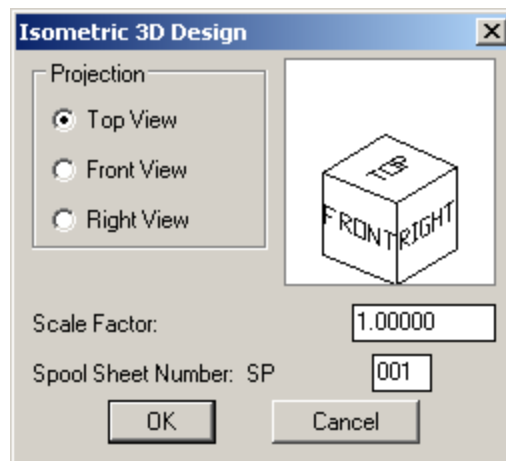

We will draw the iso in a top projection plane as illustrated by the isometric cube in the dialog box.

Keep the scale factor at 1.00, which is the same scale as the plan view.

Command: Entities to Isometrically Project:

*(Using a Crossing Window, pick runs TUTOR1 and TUTOR2.)*

Select objects: 95

Select objects: **<Return>**

*(After you have picked all the items to be included in the iso, press <Return>.)*

Location for Isometric Projection:

*(Pick a location for the iso. We placed ours above the plan view drawing. The insertion point is the top left corner of the iso.)*

While the iso is drawn, CADPIPE places a check mark and spool number on each piece of pipe or fitting included in the iso. These check marks and spool numbers. 3D DESIGN TUTORIAL 3D-30 appear on the plan view drawing. They are placed on layer SPOOL\_CHECKMARK so that you can turn them on or off.

## Label the Isometric

Use the Label Function command to label the iso drawing and then generate a summary of the labels. Set the layer to “BALLOON.”



### Pick “Auto-Labeling from the “TOOLS” — “Label Function” menu:

Command: Entities to Label:

*(Window around the complete iso drawing.)*

Select objects: Other corner: 270 found, 51 groups

Select objects: <Return>

(General Weld Neck Flange) Undo/Skip/Quit/Last Delta/New Hinge/

<Bubble location>: x210 = (0.00,0.00,1.00)

*(The program selects the first item in the set, in this case the weld neck flange. Pick a location for the center of this item’s balloon. Refer to the figure below for appropriate locations.)*

(Pipe) Undo/Skip/Quit/Last Delta/New Hinge/<Bubble location>: x210=

(0.00,0.00,1.00)

*(The next item in the run is selected. Continue picking locations for all items in iso. )*

The program labels each item with a balloon, leader, arrow, and unique number. As you pick pipe or fittings, the number automatically increments, while all like pipe and fittings receive the same balloon number.

Use the **Move Label** command to quickly move the bubbles to new positions.

*For a completely dimensioned isometric, you can use the UDE Out command to export the information on your 3D DESIGN drawing to a Universal Data Exchange file. This file can then be used in the CADPIPE ISO module to automatically generate a more detailed isometric drawing.*

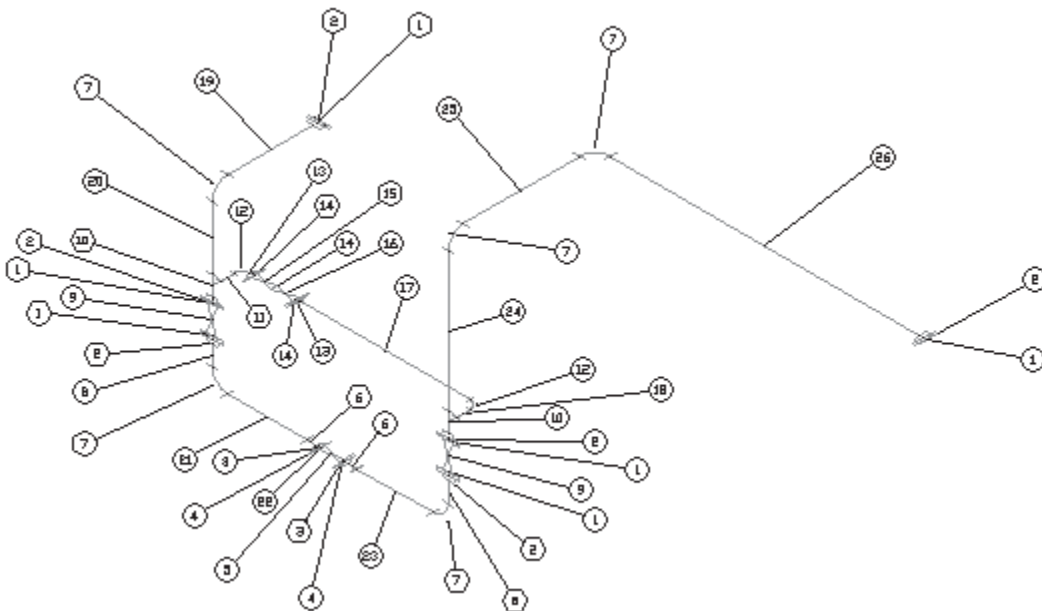

## Label Report

Next, create and save a report of the label session.



Pick “Label Report” from the “TOOLS” — “Label Function” menu

The **Label Report** dialog box lists and describes all the items that were labeled during the label session. Save this report to a file by clicking the **To File** button. You can save the label report with filename. The file is given the extension .txt and is saved to the \3DDES working directory. Save this report to **TUTOR.txt**.

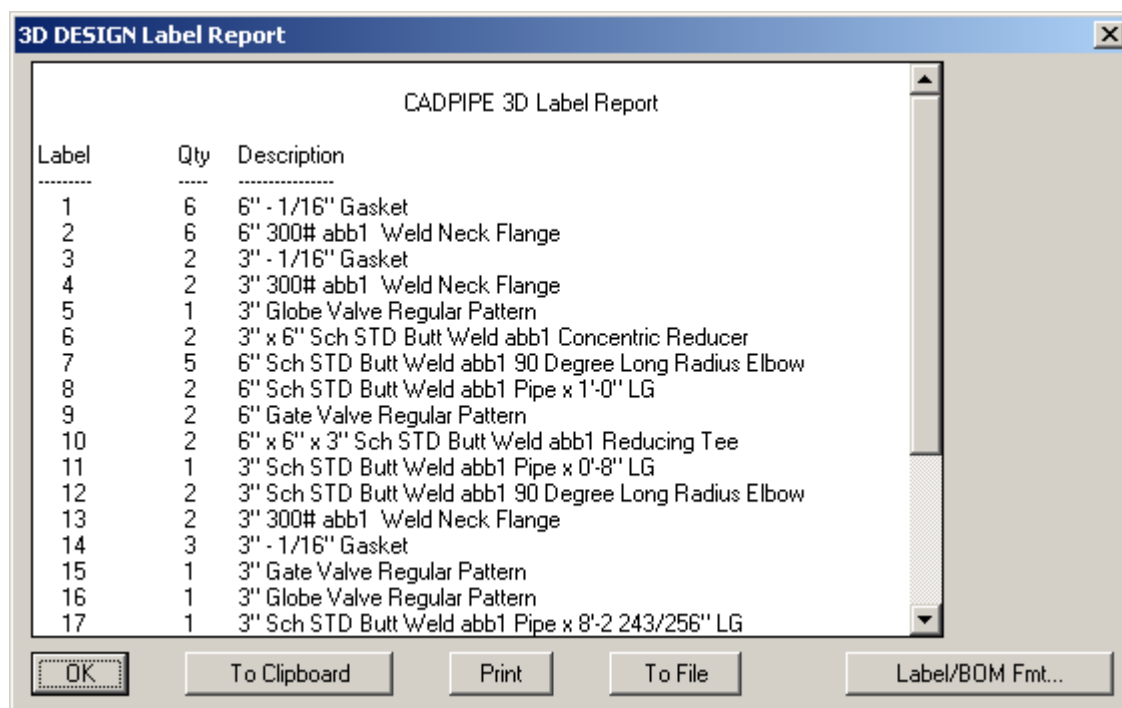

This text file can be imported to word processing or spread sheet programs and modified for use in other documents. Shortly, we will place this file on the drawing using the IMPORT TEXT command.

## Save Session

Finally, save the label session itself. This will save the label options selected and the last label number.



Pick “Save Session” from the “TOOLS” — “Label Function” menu:

You can save the label session to any spool name. The default is the drawing name. The file is given a .lbl extension and is saved to the \3DDES working directory. Save this report to **TUTOR.lbl**. Press <Return> to exit the command.

## Place Report on Drawing

---

Place the label report on the drawing using the AutoCAD **MTEXT** command.

**Type MTEXT at the command prompt.**

Create a window large enough to contain the report file to the right of the isometric drawing. *The point at which you start this Window is the point at which the top left corner of the report is placed.*

Right-click in the window and select **Import Text** from the menu.

Locate and select the TUTOR.txt file. Click OK, and the text file loads into the designated window:

CADPIPE 3D Label Report

Label	Qty	Description
1	6	6" - 1/16" Gasket
2	6	6" 300# abbl Weld Neck Flange
3	2	3" - 1/16" Gasket
4	2	3" 300# abbl Weld Neck Flange
5	1	3" Globe Valve Regular Pattern
6	2	3" x 6" Sch STD Butt Weld abbl Concentric Reducer
7	5	6" Sch STD Butt Weld abbl 90 Degree Long Radius Elbow
8	2	6" Sch STD Butt Weld abbl Pipe x 1'-0" LG
9	2	6" Gate Valve Regular Pattern
10	2	6" x 6" x 3" Sch STD Butt Weld abbl Reducing Tee
11	1	3" Sch STD Butt Weld abbl Pipe x 0'-8" LG
12	2	3" Sch STD Butt Weld abbl 90 Degree Long Radius Elbow
13	2	3" 300# abbl Weld Neck Flange
14	3	3" - 1/16" Gasket
15	1	3" Gate Valve Regular Pattern
16	1	3" Globe Valve Regular Pattern
17	1	3" Sch STD Butt Weld abbl Pipe x 8'-2 243/256" LG
18	1	3" Sch STD Butt Weld abbl Pipe x 0'-8" LG
19	1	6" Sch STD Butt Weld abbl Pipe x 4'-2 31/256" LG
20	1	6" Sch STD Butt Weld abbl Pipe x 3'-0 253/256" LG
21	1	6" Sch STD Butt Weld abbl Pipe x 3'-10 1/4" LG
22	1	3" Sch STD Butt Weld abbl Pipe x 0'-0 1/16" LG
23	1	6" Sch STD Butt Weld abbl Pipe x 3'-7 227/256" LG
24	1	6" Sch STD Butt Weld abbl Pipe x 6'-8 253/256" LG
25	1	6" Sch STD Butt Weld abbl Pipe x 5'-8" LG
26	1	6" Sch STD Butt Weld abbl Pipe x 15'-0 119/128" LG

Congratulations, you have completed the CADPIPE 3D DESIGN Tutorial drawing! You may continue drawing with CADPIPE, as there are many more features that have not been demonstrated through this Tutorial.

---